

Dehumidifier Instruction Manual

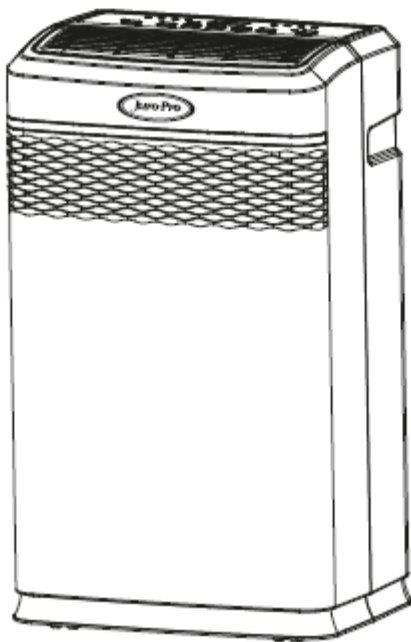

ECO II 20L WiFi



Please keep this instruction manual for future potential usage.

Contents

Please take some time to read this instruction manual and keep it for potential usage.

	Page
Warnings-----	1
Specification-----	2
Working principle-----	3
Working environment-----	4
Important safety measures-----	5
Parts of machine-----	6
Operation method-----	7-10
Protect function and Drainage-----	11-12
Wi-Fi Instructions-----	13-18
Maintenance-----	19
Repair and Storage-----	20
Problem shooting -----	21-22
Safety Instructions-----	23-26
Appendix-----	27-33

Warnings

This appliance can be used by children aged from 8 years and above and persons with reduced physical, sensory or mental capabilities or lack of experience and knowledge if they have been given supervision or instruction concerning use of the appliance in a safe way and understand the hazards involved. Children shall not play with the appliance. Cleaning and user maintenance shall not be made by children without supervision.

If the supply cord is damaged, it must be replaced by the manufacturer, its service agent or similarly qualified persons in order to avoid a hazard.

Meaning of crossed –out wheeled dustbin:

Do not dispose of electrical appliances as unsorted municipal waste, use separate collection facilities.

Contact your local government for information regarding the collection systems available.

If electrical appliances are disposed of in landfills or dumps, hazardous substances can leak into the groundwater and get into the food chain, damaging your health and well-being.



Specification Description

Model	Juro-pro Eco 20L Wi-Fi
Power	220-240V/50Hz
Nominal dehumidification	11L/Day (27°C, RH: 60%)
Dehumidifying Capacity	20L/Day (30°C, RH: 80%)
*Power input/Amp (DB 27°C, RH 60%)	320 W/ 1.40A
Compressor	rotation
Freeing medium	R134a/0.19kg
Working range	5 ~ 35°C
Water tank capacity	5.3 L
Low/High Speed	160/200 m ³ /h
Size (WxDxH)	35.8x 25.5x 60.4cm
N.W.	12.5 kg

- For the reason of technical and voltage fluctuation, data with* in the table may change. Please refer to nameplate on the machine.

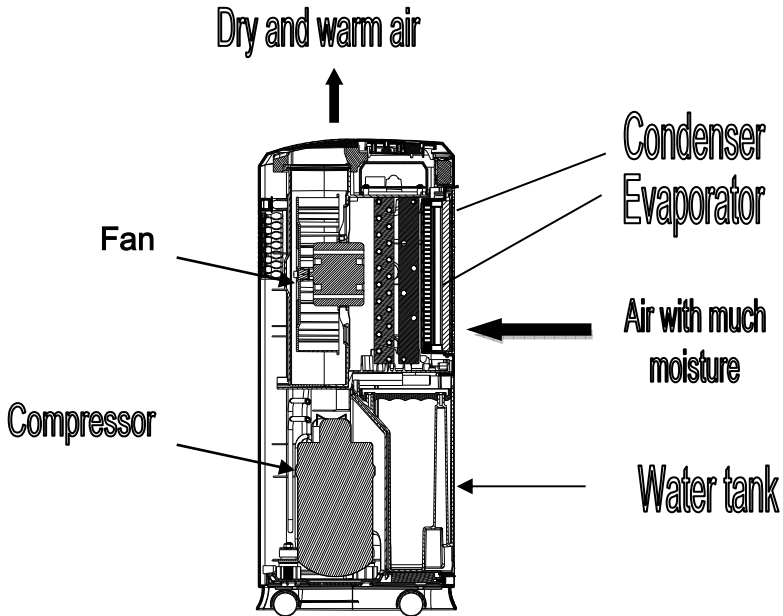

Working Principle

This product is a multi-functional mobile dehumidifier with CE and GS certification, dehumidification, air purification and dry-coating three in one, which can be set humidity level according to different requirement. Through the machine settings, the damp air flows through the body of the evaporator and radiator, and the relative humidity of the room could be controlled: the excessive moisture air flow through the evaporator, the air will condensate into water and then exhaust to the water tank, after that the dry air flow through the radiator to warm up then back to the room. So it's a cycle, the machine reduce the room humidity

Working environment

This is a movable dehumidifier, and you can set the room humidity according to requirement. It could create a healthy and comfortable environment. The machine usually used in basement, wine cellar, storage, closet. Also could be used in kitchen, library, showroom, computer room archives, living room and bedroom.

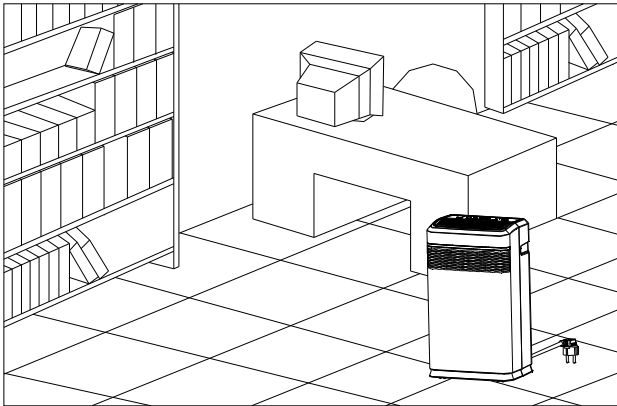
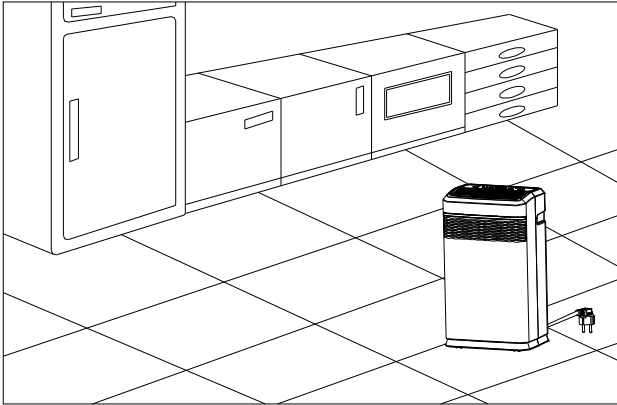

Important Safety Measures

1. Keep the machine upright on the floor.
2. After be transported or tilted (caused by cleaning), the machine need to be stop for three hours and then plugged into power.
3. Make sure there's 25CM distance around the machine.
4. Keep the outside object away from air inlet and outlet.
5. Don't pour or splash water onto the machine.
6. The power supply must accord with the rating label, and the power outlet must have a grounding port.
7. Don't plug/unplug the machine to open/close it. Use the control panel.
8. Before move the machine, you need to turn off it, unplug, and make the water tank empty.
9. Don't use bad quality or flammable cleaner on the machine.
10. When there's something wrong with the machine, turn off the machine, unplug it.
11. When the wire is broken, you need to find a recognized representative office or qualified person to replace it in order to prevent the danger.

Parts of machine

1. Air Outlet
2. Humidity Display Screen
3. Castor
4. Handle for Whole Machine
5. Control Panel
6. Air Inlet
7. Drainage
8. water tank
9. Power Wire
10. Handle of Water Tank

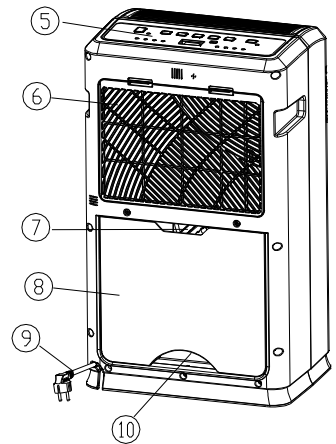
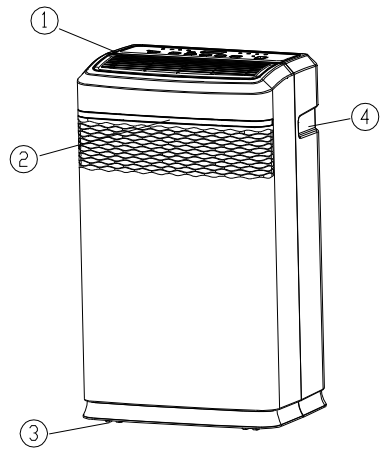

Note: The appearance diagram is only one of them. The company reserves the right to design change of the product. The product you purchased may have been improved, but it is not completely consistent with the schematic diagram of the manual, but it will not change the performance and usage.

Operation Method

● Operation Panel Icon

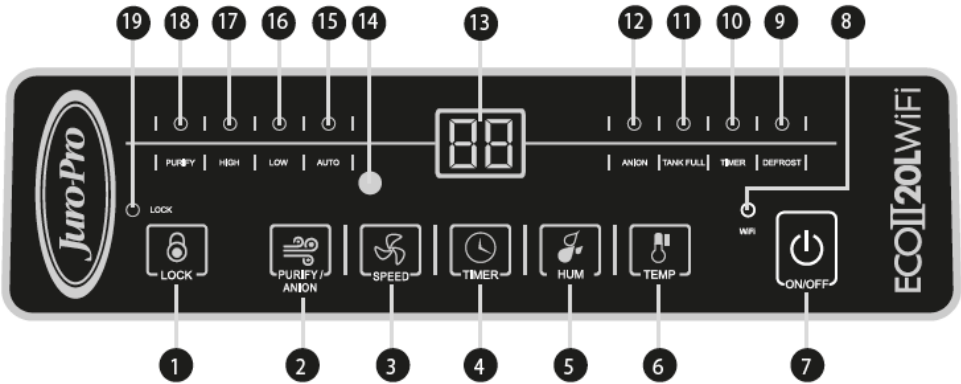

- 1.Lock button
- 2.Mode button
- 3.Speed button
- 4.Timer button
- 5.Humidity button
- 6.Temperature button
- 7.ON/OFF button
- 8.Power indicator light
- 9.Defrost indicator light
- 10.Timer indicator light
- 11.Tank full indicator light
- 12.Anion indicator light
- 13.Digital display window
- 14.Light sensor window
- 15.Auto speed indicator light
- 16.Low speed indicator light
- 17.High speed indicator light
- 18.Air purify indicator light
- 19.Lock indicator light

◆ ON/OFF

1. Connection of power, then you will hear “DI” sound (Refer to nameplate sticker on the power requirements).
2. Press “ON/OFF” button to turn on machine, then power indicator lights on. Display system shows default setting models and corresponding indicators light.
3. When machine on work, press “ON/OFF” button to stop it, then all indicators are off. (If the water tank is full, even if under the shutdown state, the water tank full light is still on.) Note: in case long idle, please pull power plug off.

◆ Lock

Short press the “Lock” button, the lock indicator lights on, this moment all buttons on the control panel are locked except the “Lock”, press other buttons are invalid.

Long press the “Lock”(about 3 seconds) under the lock condition of machine, the lock indicator lights off, all the button function are back to the normal.

◆ Air purify and dehumidify shift system

When (purify) indicator lights on, represent the machine work on the air purify condition, the fan run and the compressor stop working, the digital display show the current environmental humidity. Press “mode”, the machine work on the dehumidify state, system begin to dehumidify. Press this button repetitively that can switch between in air purification and dehumidification.

◆ Choice of airflow speed

Press the “speed” can choose three wind speed models of high, low and auto speed, after choose the corresponding indicator lights on. When “high” indicator lights on said fan work in high wind, when “low” indicator lights on said fan work in low wind, when “auto” indicators lights on said fan work in auto wind. This moment, machine will choose wind speed on the basis of detected environment status automatically.

◆ Timing function

1. When on work, press “TIMER” button to show current timing, repeat pressing it to set auto shutting down at the range of 0-24 hours (0 excluded). Starting timing, timing indicator lights on. And when setting time out, machine will be shut down automatically.
2. When off work, can preset timer. Press “TIMER” button to show current timing, repeat pressing it to set auto turning on at the range of 0-24 hours (0 excluded). Starting timing, timing indicator lights on. Digital tube display setting time, the display time will decrease by one hour. And when setting time out, machine will be turned on automatically.
3. Press and hold the “Timer” button to set the time to quickly set. The

time will automatically increase by hour. When the required timing number appears, you can let go.

◆ **Humidity setting**

Default setting humidity of machine is RH55%, press “HUM” button, display the current setting of humidity, press “HUM” button again to set humidity at the range of RH40%~80% (5% for one level), CO is continuous(regardless the environment humidity, machine will keep on the dehumidification state). After choose, digital tube twinkle several times, after confirming the selection automatically, restore to display the environment humidity. These settings can be recycled. When the machine is under auto mode, when the “auto” indicator light on, humidity is default to 55% and unadjustable.

◆ **Temperature display**

Press “TEMP” button, Monitor displays ambient temperature. Seconds later, it will show ambient humidity again.

◆ **Anion on/off**

When on work, long press “mode” button can turn on or off anion. When the “anion” indicator light on, says the anion function open. Otherwise says the anion function in the closed state.

◆ **Frost removal function**

Machine has frost removal function. When defrosting, corresponding indicator will light, compressor stops and fan still works.

◆ **Detection of full water**

When tank is full, alarm buzzing (about 5 seconds), corresponding indicator lights and machine stops working.

◆ **Humidity quality indication function**

The three-color indicator light displays the corresponding color according to the current air humidity. When the power is turned on for the first time, the indoor humidity is less than or equal to RH60%, and the display is green; when the indoor humidity is less than RH80%, it is yellow when it is greater than RH60%; when the indoor humidity is greater than or equal to RH80%, it is red. After the display, as long as the power is continuously turned on, the light is displayed as follows: when the humidity drops, the red light is when the indoor humidity is greater than RH76%, the yellow

light when the indoor humidity is less than or equal to RH76%, and the green light when the humidity is less than or equal to RH57%. When the humidity rises, it is a green light when the indoor humidity is less than or equal to RH64%, a yellow light when the humidity is greater than RH64% and less than RH84%, and a red light when the humidity is greater than or equal to RH84%. (Note: the blue part is new)

◆ Night mode function(optional)

This machine with night mode function, when detected that there is no light or the light is weak, enter night mode automatically after 5 seconds and the machine work properly, the digital display window and indicator lights on the panel are extinguished. When detected that there is light again, or the light is strong enough, machine restore all the display.

◆ The compressor stop/start protection function

Machine is in the process of running, any operation lead to the compressor stop working. The machine automatically into stop 3 minutes and then start the protection function of compressor, the compressor may not start again in 3 minutes, and other functions are running.

◆Drying function

1. The specific settings of the drying function: in the working state of the machine, set the machine to work in the dehumidification state, select the wind speed as "high", and the humidity in continuous dehumidification "CO". The clothes are placed as shown on the right, placed 30 to 50 cm from the left side of the air outlet and the top of the machine.

(Note: When using the dehumidifier to dry clothes, all clothes should not drip, otherwise the water can easily drip onto the floor or the machine. It is recommended to use a washing machine to dehydrate and hang on the mobile drying rack)

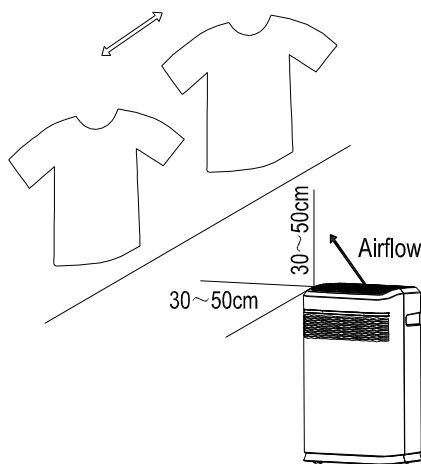

◆ **The identification function of fault protection/High and low temperature protection**

1. The coil pipe temperature sensor fault: when detected that the coil pipe temperature sensor fault, compressor and fan stop working, LED lights off, button is invalid, digital window display “E1”, after coil pipe temperature sensor return normal, machine work properly.

2. Humidity sensor fault: when detected that the humidity sensor fault, compressor and fan stop working, LED lights off, button is invalid, digital window display “E2”, after humidity sensor return normal, machine work properly.

3. Room temperature sensor failure: When the display window displays “HI” , it means that the ambient temperature is detected $>75^{\circ}\text{C}$, and when “HI” is displayed, it is usually the room temperature sensor failure. When the display window displays “LO” , it indicates that the ambient temperature is $<-9^{\circ}\text{C}$ or the ambient humidity is $<25\%$. If “LO” is displayed at ambient temperature, it is usually a room temperature sensor failure.

4. This machine has high/low temperature protection function, that is, when the temperature sensor detects that the ambient temperature is lower than 2°C , higher than or equal to 40°C , the machine does not dehumidify, the compressor stops working, and only the fan runs

◆ **Drainage**

When water in tank is full, machine will alarm and stop working automatically, then indicator light turns red, reminding user pour out water in the tank:

1. Take bar of tank, pull out gently.

2. After pouring out water, bring tank back to original position. Then machine works again. Indicator light is still lit and machine does not work if tank is not placed in correct position.

3. When removing and placing the water tank, take it with care.

◆ Continuous drainage (optional)

When machine should work for long time, please refer as follows:

1. Take tank out from back of machine. Fig.1
2. Connect a hose with inner diameter 11.5mm-12.0mm to drainage hole. Fig.2

Fig.2

3. Put tank back. (Fig.3)

Fig.1

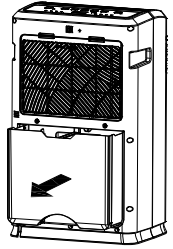

Note: in order to make sure smooth drainage of water, drainage hose should be connected in correct (Fig.2). Take care of freeze-up of hose when cold.

Fig.2

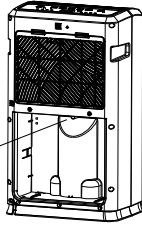
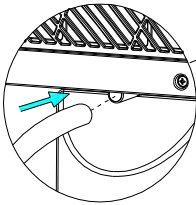
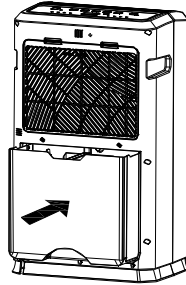

Fig.3



Wi-Fi instructions

Downloaded the app

Make sure that your mobile phone is connected to your home WiFi. And download the TuyaSmart from the App Store.



1. Manually add

Manually add mode is divided into EZ mode and AP mode :

(1) EZ Mode

1. Open the app. The following interface will appear after you register an account. And click Add Device.

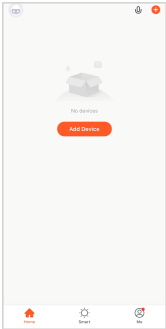

2. Select Add Manually, Small Home Appliance, and Dehumidifier to enter the following interface.



3. Enter your wifi password, click next.

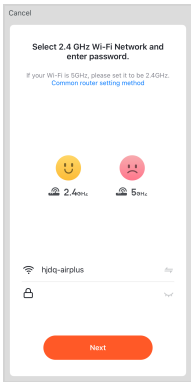

4. Select “Confirm indicator rapidly blink”, click “next”. Then waiting for connecting

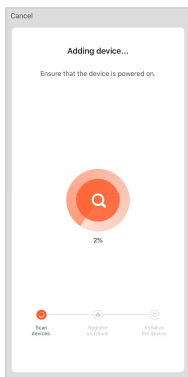
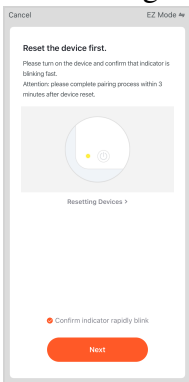

5. Congratulations, you can control the dehumidifier using your mobile phone anytime at anywhere.

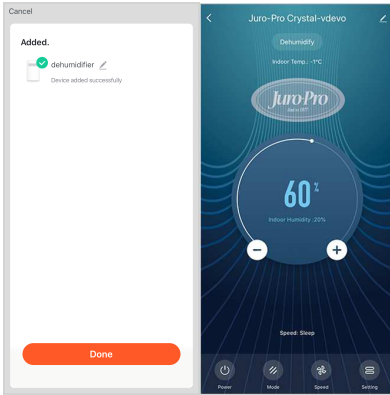

(2) AP Mode

1. Open the app. The following interface will appear after you register an account. And click Add Device.

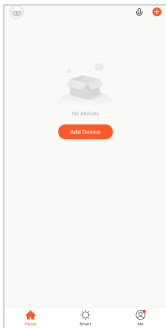

2. Select Add Manually, Small Home Appliance, and Dehumidifier to enter the following interface.

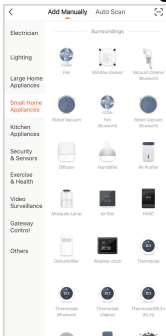

3. Enter your wifi password, click next.

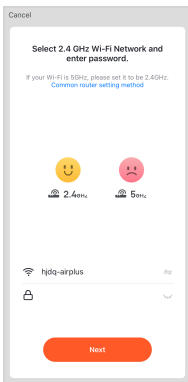

4. Press the “ON/OFF” for seconds to make the WIFI indicator slowly blink. Click EZ mode

In the upper right corner to switch the distribution network mode to AP compatible mode, check “Confirm indicator slowly blink”, then click next.

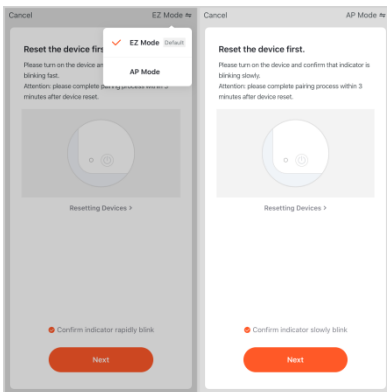

5. Connect the network SmartLife-XXXX, return to APP after successful connection, and connect the network automatically.

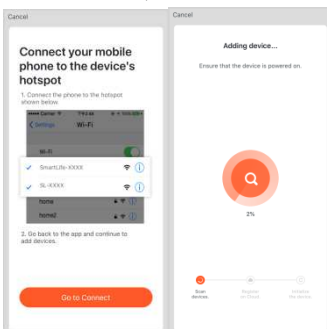

6. Congratulations, you can control the dehumidifier using your mobile

using your mobile phone anytime at anywhere.

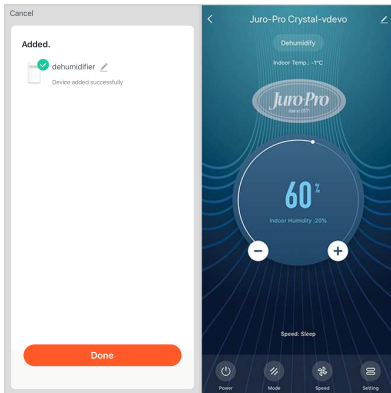

2. Add automatically

1. Open the app. The following interface will appear after you register an account. And click Add Device.

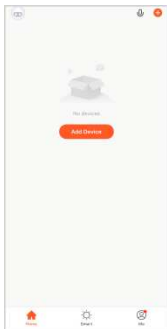

2. Select auto scan to connect the network automatically after the machine is powered on.

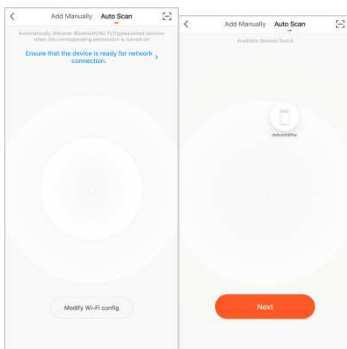

3. Click the next after successful connection, then you can control the dehumidifier using your mobile phone anytime at anywhere.

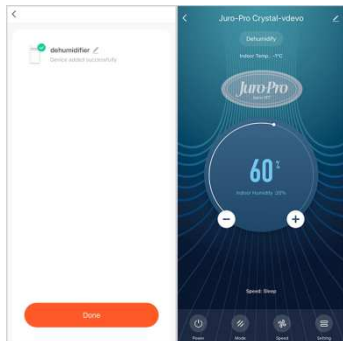

In case of APP problems, long press temperature and humidity buttons to unbind and repeat the connection process.

● Maintenance

Pull off power plug from socket before maintaining or washing.

◆ Cleaning

1. After the machine stop work for 1 hour, you can clean the body of the machine.
2. Clean machine by soft cloth
3. Do not use clean machine by volatile chemicals, gasoline, detergent chemical processed cloth or other cleaning solution, which may are harmful to machine

Notice: When cleaning, please do not wash with water directly, to avoid that water into the machine and break down.

◆ Filter Cleaning Air

This machine is equipped with primary filter and high efficiency filter. The high efficiency filter is optional.

Clean Filter

- 1.Primary filter cleaning: Remove grid, then take off dust filter from the back of machine (fig.4)
 2. Let dust off by a vacuum cleaner or brush it gently. If filter is too dusty, clean it with warm water (fig.5)
- Make sure dust filter is dry when put back to fixed position.
 - Do not expose dust filter to sun.

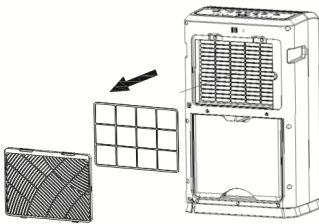

Fig.4

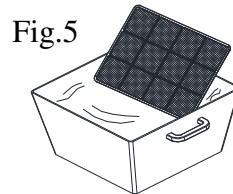

Fig.5

● **Repair**

1. The product need to repair, please find the service providers or professional staff for processing. Such as maintenance by yourself lead to damage of the body and all accident, its responsibility to the user conceit.
2. The waste which is replaced by repairing, please send to factory which is eligible for waste disposal.
3. When the service life of product is expired, should be scrapped, please send to the environmental protection professional manufacturers, shall not be arbitrarily discarded.

● **Storage**

When machine does not run for long time, please do as

follows:

1. Turn off machine, cut off power and sort out power cord.
2. Pour out tank water and wipe it.
3. Clean the filter.
4. Cover up machine and place it in one position unexposed to sun

● Problem shooting

Before calling for service, please make following check:

Problems	Possible causes
Machine does not work	<ul style="list-style-type: none"> ● Whether plug in the power? ● Whether electrical wires indoor in the power? ● Whether full water indicator is lit? (If lit, water tank is possibly full of water or not placed in correct position) ● Whether the room humidity is equal to or lower than machine settled humidity?
Machine does not dehumidify	<ul style="list-style-type: none"> ● Whether the filter is dusty, or contaminated? ● Whether Inlet or outlet is blocked? ● Whether humidity indoor is too less? ● Whether temperature indoor is lower than 5°C? ● Whether temperature indoor is higher than 40°C?
Dehumidification effect is not obvious or none	<ul style="list-style-type: none"> ● Whether opening too many windows or doors? ● Whether there are machines indoor making much humidity? ● Whether the temperature and/or humidity of room is very low?
Leaves seems unworking (there is no air discharge)	<ul style="list-style-type: none"> ● Whether filter is clogged? ● Whether the fan is stuck?
Much noise	<ul style="list-style-type: none"> ● Whether vibration caused by uneven placement of the machine or uneven floor? ● Whether filter is clogged?

▲ If the above conditions occur, the corresponding processing steps can not be resolved, or other faults occur, please contact the supplier or the

repair station, do not disassemble or repair it yourself to avoid accidents.

● Problem shooting

The following symptoms are not failure:

Symptoms	causes
Noise gets bigger when machine starts	When compressor starts, noise of compressing gets bigger.
Machine will pump out musty taste in first use	Temperature of heat ex-changer rises suddenly, leading to temporary strange smell or musty taste.
Machine echoes	If machine used in a small room, or a wooden floor room, may echo.
At the start of operation mode or switched to this mode, machine will make abnormal noise	Refrigerant before restoring stability flow may noise.
Water spots in water tank	These are left traces of water evaporation after factory dehumidification test.

Safety Instructions

Warning

- Do not use means to accelerate the defrosting process or to clean, other than those recommended by the manufacturer.
- The appliance shall be stored in a room without continuously operating ignition sources (for example: open flames, an operating gas appliance or an operating electric heater.)
- Do not pierce or burn.
- Be aware that refrigerants may not contain an odor.
- Appliance shall be installed, operated and stored in a room with a floor area larger than 12.5 m².
- Keep any required ventilation openings clear of obstruction.
- Servicing shall be performed only as recommended by the manufacturer.
- The appliance shall be stored in a well-ventilated area where the room size corresponds to the room area as specified for operation.
- Any person who is involved with working on or breaking into a refrigerant circuit should hold a current valid certificate from an industry-accredited assessment authority, which authorizes their competence to handle refrigerants safely in accordance with an industry recognized assessment specification.
- Servicing shall only be performed as recommended by the equipment manufacturer. Maintenance and repair requiring the assistance of other skilled personnel shall be carried out under the supervision of the person competent in the use of flammable refrigerants.
- All working procedure that affects safety means shall only be carried by competent persons.
- Be careful not to bump when moving to avoid leakage in the refrigeration line.



Flammable material.



Refer operators



Read technical



Read operators

**This appliance contains R290/
Propane a flammable refrigerant**

manual

manual

The maximum dosage of refrigerant is 65g

Notes:

- The dehumidifier is only suitable for indoor use, and is not suitable for other applications.
- Place the machine in a flat and dry place and keep a distance of above 50cm between the machine and the surrounding objects or walls.
- After the dehumidifier is installed, ensure that the power plug is intact and firmly plugged into the power outlet, and place the power cord orderly to prevent someone from being tripped or pulling out the plug.
- Do not put any object into the air inlet and outlet of the dehumidifier. Keep the air inlet and outlet free from obstructions.
- When drainage pipes are installed, ensure that the drainage pipes are properly connected, and are not distorted or bended.
- When moving the machine, make sure that it is in an upright position.
- The machine should stay away from gasoline, flammable gas, stoves and other heat sources.
- Don't disassemble, overhaul and modify the machine arbitrarily, otherwise it will cause a machine malfunction or even bring harm to persons and properties. To avoid danger, if a machine failure occurs, ask the manufacturer or professionals to repair it.
- Do not pull the plug to turn off the machine.
- Do not place cups or other objects on the body to prevent water or other liquids from spilling into the dehumidifier.
- Do not use insecticide sprays or other flammable substances near the dehumidifier.
- Do not wipe or wash the dehumidifier with chemical solvents such as gasoline and alcohol. When you need to clean the air conditioning, you must disconnect the power supply, and clean it with a half-wet soft cloth. If the machine is really dirty, scrub with a mild detergent.
- This appliance is not intended for use by persons (including children) with reduced physical, sensory or mental capabilities, or lack of experience and knowledge, unless they have been given supervision or instruction concerning use of the appliance by a person responsible for their safety. (Except for the humidifier with CE-MARKING)

- Children should be supervised to ensure that they do not play with the appliance. (Except for the humidifier with CE-MARKING)
- The appliance can be used by children aged from 8 years and above and persons with reduced physical, sensory or mental capabilities if they have been given supervision or instruction concerning use of the appliance in a safe way and understand the hazards involved. Children shall not play with the appliance. Cleaning and maintenance shall not be made by children without supervision (Only for the humidifier with CE-MARKING)
- If the supply cord is damaged, it must be replaced by the manufacturer, its service agent or similarly qualified persons in order to avoid a hazard.

Transportation, marking and storage for units

1. Transport of equipment containing flammable refrigerants
Compliance with the transport regulations
2. Marking of equipment using signs
Compliance with local regulations
3. Disposal of equipment using flammable refrigerants
Compliance with national regulations
4. Storage of equipment/appliances
The storage of equipment should be in accordance with the manufacturer's instructions.
5. Storage of packed (unsold) equipment
Storage package protection should be constructed such that mechanical damage to the equipment inside the package will not cause a leak of the refrigerant charge.
The maximum number of pieces of equipment permitted to be stored together will be determined by local regulations.
The appliance shall be stored so as to prevent mechanical damage from occurring
Remark: The best operating ambient temperature is 5-35 ° C.

The fuse mode is 4T or 4F or 334 or L3CT, the specification is AC250V, 3.15A.

Appliance is filled with flammable gas R290, and the maximum charge of refrigerant is 65g. GWP value of R290 refrigerant is 3.

Any repairs you need, contact the nearest authorized Service Centre and strictly follow manufacturer's instruction only

APPENDIX

1. Information on servicing

1) Checks to the area

Prior to beginning work on systems containing flammable refrigerants, safety checks are necessary to ensure that the risk of ignition is minimized. For repair to the refrigerating system, the following precautions shall be complied with prior to conducting work on the system.

2) Work procedure

Work shall be undertaken under a controlled procedure so as to minimize the risk of a flammable gas or vapor being present while the work is being performed.

3) General work area

All maintenance staff and others working in the local area shall be instructed on the nature of work being carried out. Work in confined spaces shall be avoided. The area around the workspace shall be sectioned off. Ensure that the conditions within the area have been made safe by control of flammable material.

4) Checking for presence of refrigerant

The area shall be checked with an appropriate refrigerant detector prior to and during work, to ensure the technician is aware of potentially flammable atmospheres. Ensure that the leak detection equipment being used is suitable for use with flammable refrigerants, i.e. non-sparking, adequately sealed or intrinsically safe.

5) Presence of fire extinguisher

If any hot work is to be conducted on the refrigeration equipment or any associated parts, appropriate fire extinguishing equipment shall be available to hand. Have a dry powder or CO₂ fire extinguisher adjacent to the charging area.

6) No ignition sources

No person carrying out work in relation to a refrigeration system which involves exposing any pipe work that contains or has contained flammable refrigerant shall use any sources of ignition in such a manner that it may lead to the risk of fire or explosion. All possible ignition sources, including cigarette smoking, should be kept sufficiently far away from the site of installation, repairing, removing and disposal, during which flammable refrigerant can possibly be released to the surrounding space.

Prior to work taking place, the area around the equipment is to be surveyed to make sure that there are no flammable hazards or ignition risks. “No Smoking” signs shall

be displayed.

7) Ventilated area

Ensure that the area is in the open or that it is adequately ventilated before breaking into the system or conducting any hot work. A degree of ventilation shall continue during the period that the work is carried out. The ventilation should safely disperse any released refrigerant and preferably expel it externally into the atmosphere.

8) Checks to the refrigeration equipment

Where electrical components are being changed, they shall be fit for the purpose and to the correct specification. At all times the manufacturer's maintenance and service guidelines shall be followed. If in doubt consult the manufacturer's technical department for assistance.

The following checks shall be applied to installations using flammable refrigerants:

- a) The charge size is in accordance with the room size within which the refrigerant containing parts are installed.
- b) The ventilation machinery and outlets are operating adequately and are not obstructed.
- c) If an indirect refrigerating circuit is being used, the secondary circuit shall be checked for the presence of refrigerant.
- d) Marking to the equipment continues to be visible and legible. Markings and signs that are illegible shall be corrected.
- e) Refrigeration pipe or components are installed in a position where they are unlikely to be exposed to any substance which may corrode refrigerant containing components, unless the components are constructed of materials which are inherently resistant to being corroded or are suitably protected against being so corroded.

9) Checks to electrical devices

Repair and maintenance to electrical components shall include initial safety checks and component inspection procedures. If a fault exists that could compromise safety, then no electrical supply shall be connected to the circuit until it is satisfactorily dealt with. If the fault cannot be corrected immediately but it is necessary to continue operation, an adequate temporary solution shall be used. This shall be reported to the owner of the equipment so all parties are advised.

Initial safety checks shall include:

- a) That capacitors are discharged: this shall be done in a safe manner to avoid

possibility of sparking.

- b) That there no live electrical components and wiring are exposed while charging, recovering or purging the system.
- c) That there is continuity of earth bonding.

2. Repairs to sealed components

1) During repairs to sealed components, all electrical supplies shall be disconnected from the equipment being worked upon prior to any removal of sealed covers, etc. If it is absolutely necessary to have an electrical supply to equipment during servicing, then a permanently operating form of leak detection shall be located at the most critical point to warn of a potentially hazardous situation.

2) Particular attention shall be paid to the following to ensure that by working on electrical components, the casing is not altered in such a way that the level of protection is affected. This shall include damage to cables, excessive number of connections, terminals not made to original specification, damage to seals, incorrect fitting of glands, etc. Ensure that apparatus is mounted securely.

Ensure that seals or sealing materials have not degraded such that they no longer serve the purpose of preventing the ingress of flammable atmospheres.

Replacement parts shall be in accordance with the manufacturer's specifications.

NOTE: The use of silicon sealant may inhibit the effectiveness of some types of leak detection equipment. Intrinsically safe components do not have to be isolated prior to working on them.

3. Repair to intrinsically safe components

Do not apply any permanent inductive or capacitance loads to the circuit without ensuring that this will not exceed the permissible voltage and current permitted for the equipment in use.

Intrinsically safe components are the only types that can be worked on while live in the presence of a flammable atmosphere. The test apparatus shall be at the correct rating.

Replace components only with parts specified by the manufacturer. Other parts may result in the ignition of refrigerant in the atmosphere from a leak.

4. Cabling

Check that cabling will not be subject to wear, corrosion, excessive pressure, vibration, sharp edges or any other adverse environmental effects. The check shall

also take into account the effects of aging or continual vibration from sources such as compressors or fans.

5. Detection of flammable refrigerants

Under no circumstances shall potential sources of ignition be used in the searching for or detection of refrigerant leaks. A halide torch (or any other detector using a naked flame) shall not be used.

6. Leak detection methods

The following leak detection methods are deemed acceptable for systems containing flammable refrigerants.

Electronic leak detectors shall be used to detect flammable refrigerants, but the sensitivity may not be adequate, or may need re-calibration. (Detection equipment shall be calibrated in a refrigerant-free area.) Ensure that the detector is not a potential source of ignition and is suitable for the refrigerant used. Leak detection equipment shall be set at a percentage of the LFL of the refrigerant and shall be calibrated to the refrigerant employed and the appropriate percentage of gas (25 % maximum) is confirmed.

Leak detection fluids are suitable for use with most refrigerants but the use of detergents containing chlorine shall be avoided as the chlorine may react with the refrigerant and corrode the copper pipe-work.

If a leak is suspected, all naked flames shall be removed/ extinguished.

If a leakage of refrigerant is found which requires brazing, all of the refrigerant shall be recovered from the system, or isolated (by means of shut off valves) in a part of the system remote from the leak. Oxygen free nitrogen (OFN) shall then be purged through the system both before and during the brazing process.

7. Removal and evacuation

When breaking into the refrigerant circuit to make repairs – or for any other purpose –conventional procedures shall be used. However, it is important that best practice is followed since flammability is a consideration. The following procedure shall be adhered to:

- 1) Remove refrigerant.
- 2) Purge the circuit with inert gas.
- 3) Evacuate.
- 4) Purge again with inert gas.

5) Open the circuit by cutting or brazing.

The refrigerant charge shall be recovered into the correct recovery cylinders. The system shall be “flushed” with OFN to render the unit safe. This process may need to be repeated several times. Compressed air or oxygen shall not be used for this task.

Flushing shall be achieved by breaking the vacuum in the system with OFN and continuing to fill until the working pressure is achieved, then venting to atmosphere, and finally pulling down to a vacuum. This process shall be repeated until no refrigerant is within the system. When the final OFN charge is used, the system shall be vented down to atmospheric pressure to enable work to take place. This operation is absolutely vital if brazing operations on the pipe-work are to take place.

Ensure that the outlet for the vacuum pump is not close to any ignition sources and there is ventilation available.

8. Charging procedures

In addition to conventional charging procedures, the following requirements shall be followed.

- 1) Ensure that contamination of different refrigerants does not occur when using charging equipment. Hoses or lines shall be as short as possible to minimize the amount of refrigerant contained in them.
- 2) Cylinders shall be kept upright.
- 3) Ensure that the refrigeration system is earthed prior to charging the system with refrigerant.
- 4) Label the system when charging is complete (if not already).
- 5) Extreme care shall be taken not to overfill the refrigeration system.

Prior to recharging the system it shall be pressure tested with OFN. The system shall be leak tested on completion of charging but prior to commissioning. A follow up leak test shall be carried out prior to leaving the site.

9. Decommissioning

Before carrying out this procedure, it is essential that the technician is completely familiar with the equipment and all its detail. It is recommended good practice that all refrigerants are recovered safely. Prior to the task being carried out, an oil and refrigerant sample shall be taken in case analysis is required prior to re-use of reclaimed refrigerant. It is essential that electrical power is available before the task is commenced.

- 1) Become familiar with the equipment and its operation.

- 2) Isolate system electrically.
- 3) Before attempting the procedure ensure that:
 - a) Mechanical handling equipment is available, if required, for handling refrigerant cylinders.
 - b) All personal protective equipment is available and being used correctly.
 - c) The recovery process is supervised at all times by a competent person.
 - d) Recovery equipment and cylinders conform to the appropriate standards.
- 4) Pump down refrigerant system, if possible.
- 5) If a vacuum is not possible, make a manifold so that refrigerant can be removed from various parts of the system.
- 6) Make sure that cylinder is situated on the scales before recovery takes place.
- 7) Start the recovery machine and operate in accordance with manufacturer's instructions.
- 8) Do not overfill cylinders. (No more than 80 % volume liquid charge).
- 9) Do not exceed the maximum working pressure of the cylinder, even temporarily.

- 10) When the cylinders have been filled correctly and the process completed, make sure that the cylinders and the equipment are removed from site promptly and all isolation valves on the equipment are closed off.
- 11) Recovered refrigerant shall not be charged into another refrigeration system unless it has been cleaned and checked.

10. Labeling

Equipment shall be labeled stating that it has been de-commissioned and emptied of refrigerant. The label shall be dated and signed. Ensure that there are labels on the equipment stating the equipment contains flammable refrigerant.

11. Recovery

When removing refrigerant from a system, either for servicing or decommissioning, it is recommended good practice that all refrigerants are removed safely.

When transferring refrigerant into cylinders, ensure that only appropriate refrigerant recovery cylinders are employed. Ensure that the correct number of cylinders for holding the total system charge is available. All cylinders to be used are designated for the recovered refrigerant and labeled for that refrigerant (i.e. special cylinders for the recovery of refrigerant). Cylinders shall be complete with pressure relief valve and associated shut-off valves in good working order. Empty recovery cylinders are

evacuated and, if possible, cooled before recovery occurs.

The recovery equipment shall be in good working order with a set of instructions concerning the equipment that is at hand and shall be suitable for the recovery of flammable refrigerants. In addition, a set of calibrated weighing scales shall be available and in good working order. Hoses shall be complete with leak-free disconnect couplings and in good condition. Before using the recovery machine, check that it is in satisfactory working order, has been properly maintained and that any associated electrical components are sealed to prevent ignition in the event of a refrigerant release. Consult manufacturer if in doubt.

The recovered refrigerant shall be returned to the refrigerant supplier in the correct recovery cylinder, and the relevant Waste Transfer Note arranged. Do not mix refrigerants in recovery units and especially not in cylinders.

If compressors or compressor oils are to be removed, ensure that they have been evacuated to an acceptable level to make certain that flammable refrigerant does not remain within the lubricant. The evacuation process shall be carried out prior to returning the compressor to the suppliers. Only electric heating to the compressor body shall be employed to accelerate this process. When oil is drained from a system, it shall be carried out safely.



Correct Disposal of this product

This marking indicates that the product should not be disposed with other household wastes throughout the EU. To prevent possible harm to the environment or human health from uncontrolled waste disposal, recycle it responsibly to promote the sustainable reuse of material resources. To return your used device, please use the return and collection systems or contact the retailer where the product was purchased. They can take this product for environmentally safe recycling.