

# Instruction Manual Dehumidifier

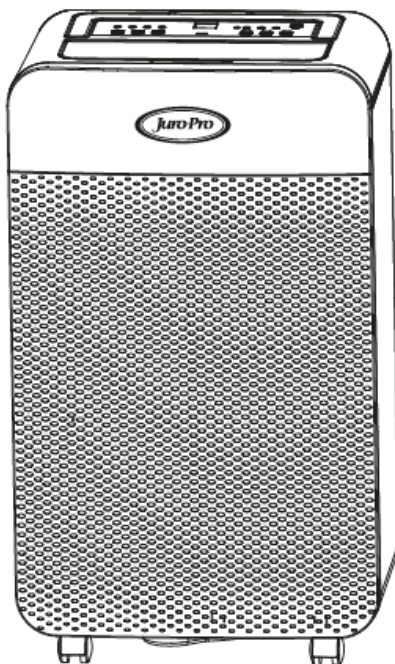

*Perla* II 25L WiFi



**Please keep this instruction manual for future potential usage.**

# Contents

Please take some time to read this instruction manual and keep it for potential usage.

	Page
Warnings-----	1
Specification-----	2
Working principle-----	3
Working environment-----	4
Important Safety Measures-----	5
Body of machine-----	6
Operation Method-----	7-9
Wi-Fi Instructions -----	10-13
Drainage-----	14-15
Maintenance-----	16
Storage-----	17
Problem shooting-----	18-19
Safety Instructions-----	20-23
Appendix-----	24-30

## Warnings

**This appliance can be used by children aged from 8 years and above and persons with reduced physical, sensory or mental capabilities or lack of experience and knowledge if they have been given supervision or instruction concerning use of the appliance in a safe way and understand the hazards involved. Children shall not play with the appliance. Cleaning and user maintenance shall not be made by children without supervision.**

**If the supply cord is damaged, it must be replaced by the manufacturer, its service agent or similarly qualified persons in order to avoid a hazard.**

**Meaning of crossed –out wheeled dustbin:**

**Do not dispose of electrical appliances as unsorted municipal waste, use separate collection facilities.**

**Contact your local government for information regarding the collection systems available.**

**If electrical appliances are disposed of in landfills or dumps, hazardous substances can leak into the groundwater and get into the food chain, damaging your health and well-being.**

**When replacing old appliances with new ones, the retailer is legally obligated to take back your old appliance for disposals at least free of charge.**



## Specification Description

<b>Model</b>	<b>Juro-Pro Perla II 25L WiFi</b>
Power	220-240V/50Hz
Test Environment	DB 30°C, RH 80%
Dehumidifying Capacity	25 L/day
*Power input/Amp (DB 27°C, RH 60%)	270W
Compressor	rotation
Refrigerant	R290
Working range	5 ~ 35°C
Water tank capacity	4.1 L
Low/High Speed	160/200 m <sup>3</sup> /h
Size (WxDxH)	355 x 254 x 593 mm
N.W.	14.0 kg/s

- For the reason of technical and voltage fluctuation, data with\* in the table may change. Please refer to nameplate on the machine.

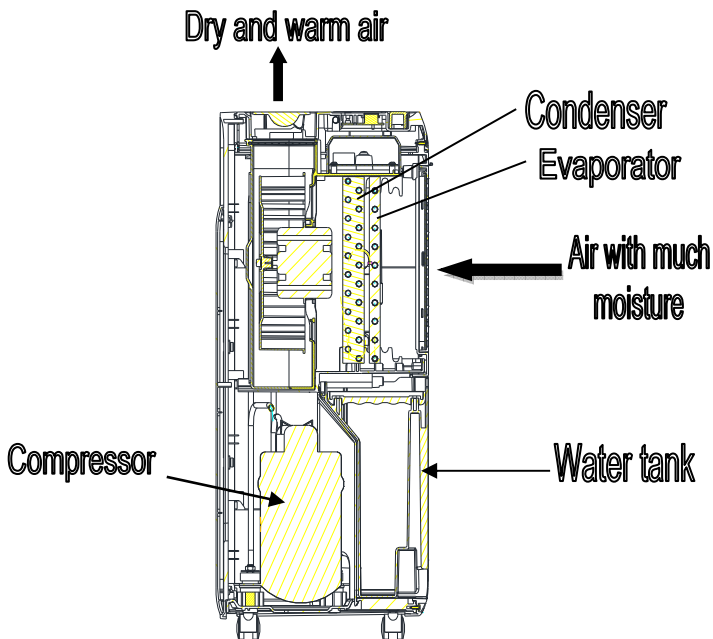

### **Working Principle**

This product is multifunctional dehumidifier, which can be set humidity level according to your different requirements. Through to the machine's settings, the damp air flows through the body of the evaporator and radiator, and then the relative humidity of the room could be controlled: the excessive moisture air flow through the evaporator, the air will condensate into water and then exhaust to the water tank, after that the dry air flow through the radiator to warm up and then back to the room. So it's a cycle, the machine reduce the room's humidity

## **Working environment**

This is a multi-functional dehumidifier, and you can set the room humidity according to your requirements. It could create a healthy and comfortable environment. The machine usually be used in basement, wine cellar, storage, and closet. It also could be used in kitchen, library, showroom, computer room, archives, living room and bedroom.

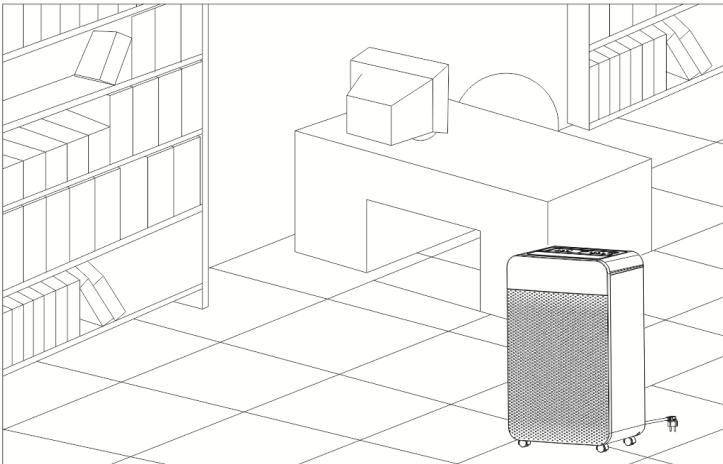
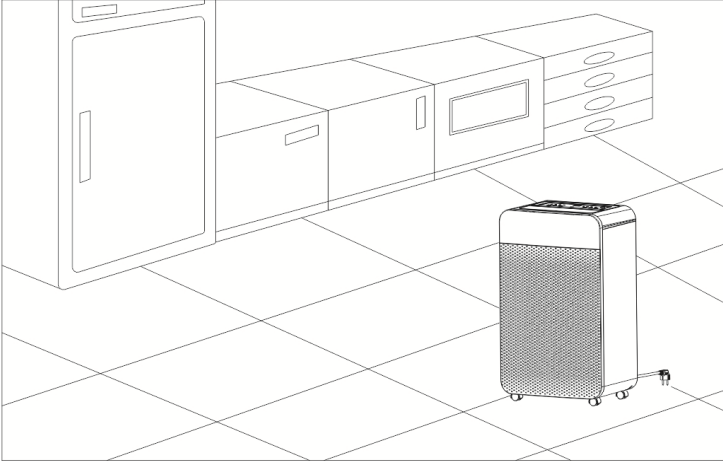

## **Important Safety Measures**

1. Keep the machine upright on the floor.
2. After be transported or tilted (caused by cleaning), the machine need to be stopped for an hour and then you can plugged it into power.
3. Make sure there's 25CM distance around the machine.
4. Keep the outside object away from air inlet and outlet.
5. Don't pour or splash water onto the machine.
6. The power supply must be accorded to the rating label.
7. Don't plug/unplug the machine to open/close it. Use the control panel.
8. Before move the machine, you need to turn off it, unplug, and make the water tank empty.
9. If the filter is dirty, it's better to clean it. When the filter is clean, the machine works better.
10. Don't use bad quality or flammable cleaner on the machine.
11. When there's something wrong with the machine, turn off the machine, unplug it.
12. When the wire is broken, you need to find a recognized reprehensive office or qualified person to replace it in order to prevent the danger.

## Body of machine

1. Handle for whole machine.
2. Control Panel
3. Air Outlet
4. Air Inlet
5. Frame of Filter
6. Drainage
7. Water Tank
8. Power wire
9. Handle of water tank
10. Caster

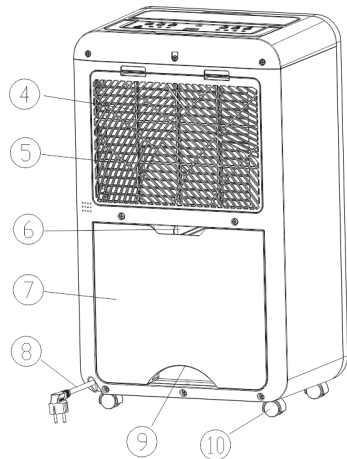
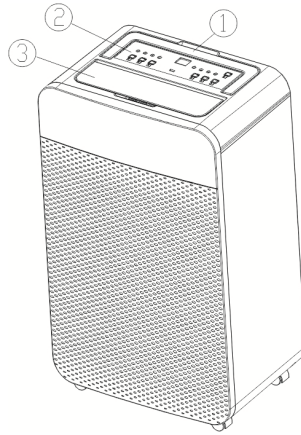

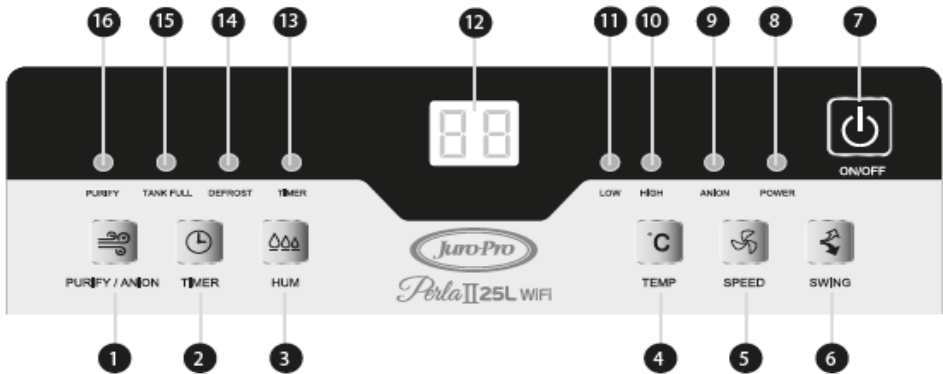

# Operation Method



## ● Operation Instruction

### ◆ ON/OFF

1. Connecting to the power (refer to nameplate sticker on the power requirements), press “” button to turn on the machine, then the power indicator lights. The display system shows the acquiescent setting models and corresponding indicators light.

2. When the machine is on work, press “” button to stop it, then all indicators are off. (Note: in case of long idle, please pull the power plug off).

### ◆ Timing function



1. When on work, press “” button to show current timing, repeat pressing it to set auto shutting down at the range of 0-24 hours (0 excluded). Starting timing, timing indicator lights. And when setting time is out, the machine will be shut down automatically.

2. When off work, press “” button to show current timing, repeat pressing it to set auto shutting down at the range of 0-24 hours (0

excluded). Starting timing, timing indicator lights. And when setting time out, machine will be turned on automatically.

7

◆ Humidity setting

Acquiescent setting humidity of machine is RH55%, press “” button, displaying the current setting of humidity, press “” button again to set humidity at the range of RH40%~80% (5% for one level) , CO is continuous. These settings can be recycled.

◆ Temperature display

Press “” button, the monitor displays the ambient temperature. Seconds later, it will show ambient humidity again.

◆ Choice of airflow speed

Press “” button to choose high or low airflow speed. Corresponding Indicator lights show the corresponding airflow speed.

◆ Setting swing (optional)

When machine is on work, press “” button to let air flow back and front, and press this button again to stop this function.

◆ Anion (optional)

When machine is on work, Long pressing “” button for 3 minutes can open or close the anion function.

◆ Long press  for more than 3 seconds to enter the Wifi distribution network (see the description of the rear network connection for details)

◆ Defrosting function

Machine has defrosting function. When defrosting, corresponding indicator will light, compressor stops and fan still works.

◆ Detection of full water

When tank is full, alarm buzzing, corresponding indicator lights and machine stops working.



8

### ◆ Shift of air purification and dehumidification

You can press the “” to choose air purification mode or dehumidification mode. When the purifying indicator light is on, it means the machine is working in the air purifying mode and the fan is running while the compressor stops. Press this button repetitively can switch between air purification mode and dehumidification mode.

### ◆ Clothes drying function

The setting of clothes drying function: when the machine is on work, press

“” button and set the dehumidification to “CO” then press “” to

choose high speed. About the clothes position please see the right picture, on the left side of the outlet and 30~50cm from top of machine. (Attention: when use clothes drying function, all clothes can't drop water, otherwise the water will drop on the floor or machine. We advise you to use the washing machine to dehydrate the clothes and hang on the mobile clothes hanger.)

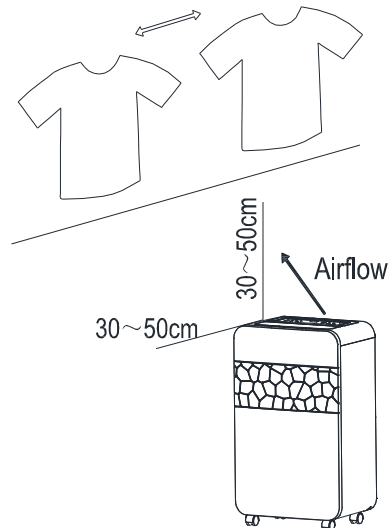

## ◆ WIFI configuration

After the WIFI connection is successful, the appliance can be remotely controlled by the mobile phone. As long as the mobile phone can access the Internet, no matter where you are, it is convenient to perform a series of settings on the machine, and the home humidity is under your control. Distribution network operation is as follows:

### 1. Install APP software

Make sure the phone is connected to Wi-Fi, scan the QR code on the body, manual or carton with the scanning software, download and install the APP (Note: data traffic will be generated under 2G/3G/4G network).

### 2. Login APP

Open the app, log in for the first time, enter the phone number, get the verification code and fill in, select "Read and agree to the user agreement and privacy terms" to log in to the app. You can also use the email address to register an account in the email interface. After successful registration, enter the email address and password to log in to the APP.

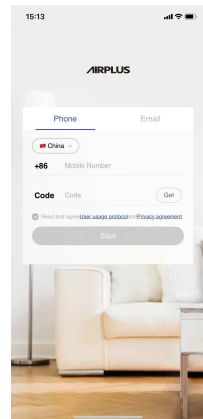

### 3. Add device

Click the "+" icon in the top right corner and select the "Add device" option. If you add it for the first time, you can also click on the "Add Device" option under the Experience Center. Please try AP Mode or AirLink Mode to connect, depending on the production date of your appliance.

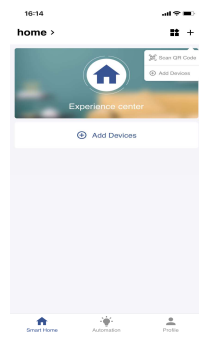

## 4. The device powered

After confirming that the machine is connected to the power supply, select the device with power on the APP interface and click Next.

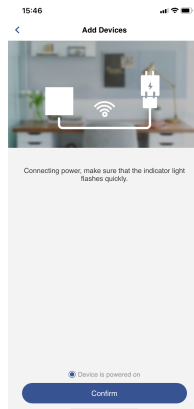

## 5. Configure network

Press the machine "on key" for more than 3 seconds until you hear a click, the power indicator flashes at a faster frequency, select the WiFi network to which the device is connected, enter the password, and click Next to configure the network.

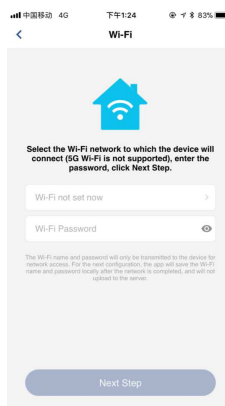

## 6. Network access

During the networking of the machine, the flashing of the power indicator light gradually slows down. This process indicates that the machine is accessing the Internet. The networking process is usually completed in about one minute, and the progress of the

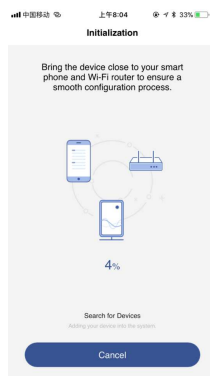

networking is also displayed on the APP.

## 7. Configure network success

After the networking is successful, if it is in the power-on state, the power indicator light is on for one second and off for five seconds; if it is in power-off state, the power indicator is off. At the same time, the APP prompts the network to be successful, check the device name and click OK to confirm the entry to the main interface.

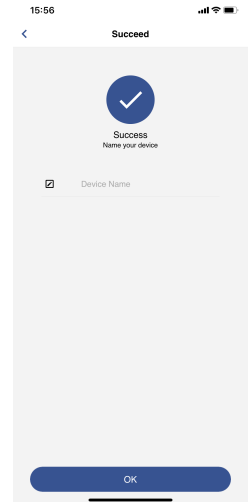

## 8. Enter the main interface

In the main interface, select and open the added device to view the working status of the machine and make a series of settings for the machine.

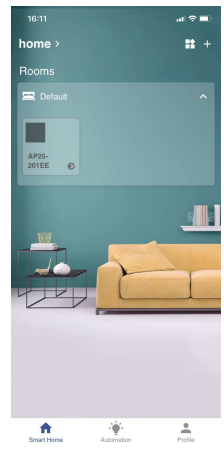

## ◆ **Dismiss the network**

According to your actual situation, if you no longer need to control the machine through the mobile phone, you can forcibly release the binding between the machine and the APP and the network. The specific operation is as follows: long press the “wind speed” button to hear the “Di” sound, the network is successfully solved. At this time, the device information originally added in the APP software is automatically eliminated. If you want to control the machine again with software, you can re-distribute the network as described above.

### **Tips:**

1. If the distribution network fails, please check if your network signal is normal, whether the product has entered the distribution network setting, whether the machine is connected to another mobile phone, etc., find out the reason and re-distribute the network.
2. Due to the continuous update of the software, the description of the above distribution network may not be the same as the software display. Please refer to the actual software display.

## ◆ Drainage

When water in tank is full, machine will alarm and stop working automatically, then indicator light turns red, reminding user pour out water in the tank:

1. Take bar of tank, pull out gently.
2. After pouring out water, bring tank back to original position. Then machine works again. Indicator light is still lit and machine does not work if tank is not placed in correct position.

## ◆ Continuous drainage(optional)

When machine should work for long time, please refer as below:

1. Take tank out from back of machine.
2. Connect a hose with inner diameter 11.5mm to drainage hole. Fig.2
3. Put tank back. (Fig.3)

Note: in order to make sure smooth drainage of water, drainage hose should be connected in correct. Take care of freeze-up of hose when cold.  
Fig.1

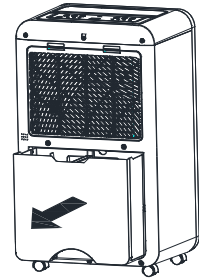

Fig.

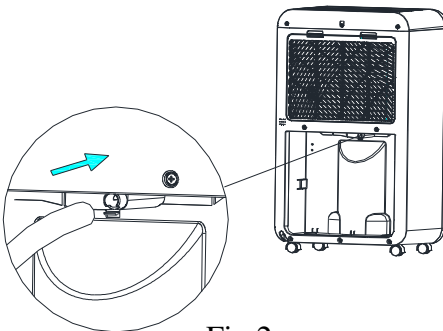

Fig.2

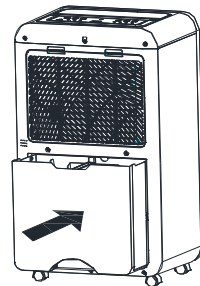

Fig.3

### ◆ **Fault identification code**

1. Coil temperature sensor failure: When the coil temperature sensor fault is detected, the compressor stops, the fan stops, the LED light goes out, the button is invalid, and the humidity display window displays “E1”. After the coil temperature sensor returns to normal, the machine works normally.

2. Humidity sensor failure: When the humidity sensor is detected, the compressor stops, the fan stops, the LED light goes out, the button is invalid, and the humidity display window displays “E2”. After the humidity sensor returns to normal, the machine works normally.

## ● Maintenance

Pull off power plug from socket before maintaining or washing.

### ◆ Cleaning

1. Clean machine by soft cloth
2. Do not clean machine by volatile chemicals, gasoline, detergent chemical processed cloth or other cleaning solution, which may be harmful to machine.

## Filter Cleaning

This machine is equipped with at least one filter,

1. Filter blocking dust
2. Active carbon filters (optional)

### Cleaning

1.dust filter cleaning: remove grid, then take off dust filter from the back of machine ( fig.4 )

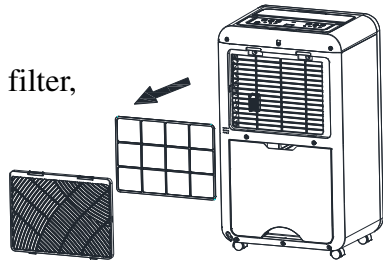

Fig.4

2.Let dust off by a vacuum cleaner or brush it gently. If filter is too dusty, clean it with warm water ( fig.5 )

- Make sure dust filter is dry when put back to the fixed position.
- Do not expose dust filter to sun.

Inner carbon filter cleaning: take off carbon filter from inlet grid, Let dust off by a vacuum cleaner or brush it gently. Do not wash it by water and not let it be exposed to sun. Replace one carbon filter semi-annually.

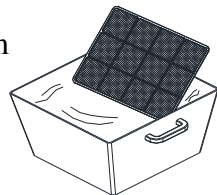

Fig.5

## ● Storage

**When machine does not run for long time, please do as follows:**

1. Turn off machine, cut off power and sort out power cord.
2. Pour out tank water and wipe it.
3. Clean the filter.
4. Cover up machine and place it in one position unexposed to sun

## Problem shooting

Before calling for service, please make following check:

Problems	Possible causes
Machine does not work	<ul style="list-style-type: none"><li>● Whether plug in the power?</li><li>● Whether electrical wires indoor in the power?</li><li>● Whether full water indicator is lit? (If lit, water tank is possibly full of water or not placed in correct position)</li><li>● Whether temperature indoor is lower than 5°C?</li></ul>
Machine does not remove moisture	<ul style="list-style-type: none"><li>● Whether the filter is dusty, or contaminated?</li><li>● Whether Inlet or outlet is blocked?</li><li>● Whether humidity indoor is too less?</li></ul>
Dehumidification effect is not obvious	<ul style="list-style-type: none"><li>● Whether opening too many windows or doors?</li><li>● Whether there are machines indoor making much humidity?</li></ul>
Leaves seems unworking	<ul style="list-style-type: none"><li>● Whether filter is clogged?</li></ul>
Much noise	<ul style="list-style-type: none"><li>● Whether vibration caused by uneven placement of the machine?</li><li>● Whether the machine is not even on uneven floor?</li></ul>

- Users can not repair or disassemble the product.

## Problem shooting

The following symptoms are not failure:

Symptoms	causes
Noise gets bigger when machine starts	When compressor starts, noise of compressing gets bigger.
Machine will pump out musty taste in first use	Temperature of heat exchanger rises suddenly, leading to temporary strange smell or musty taste.
Machine echoes	If machine used in a small room, or a wooden floor room, may echo.
At the start of operation mode or switched to this mode, machine will make abnormal noise	Refrigerant before restoring stability flow may noise.
Water spots in water tank	These are left traces of water evaporation after factory dehumidification test.

## Safety Instructions

### Warning

- Do not use means to accelerate the defrosting process or to clean, other than those recommended by the manufacturer.
- The appliance shall be stored in a room without continuously operating ignition sources (for example: open flames, an operating gas appliance or an operating electric heater.)
- Do not pierce or burn.
- Be aware that refrigerants may not contain an odor.
- Appliance shall be installed, operated and stored in a room with a floor area larger than 12.5 m<sup>2</sup>.
- Keep any required ventilation openings clear of obstruction.
- Servicing shall be performed only as recommended by the manufacturer.
- The appliance shall be stored in a well-ventilated area where the room size corresponds to the room area as specified for operation.
- Any person who is involved with working on or breaking into a refrigerant circuit should hold a current valid certificate from an industry-accredited assessment authority, which authorizes their competence to handle refrigerants safely in accordance with an industry recognized assessment specification.
- Servicing shall only be performed as recommended by the equipment manufacturer. Maintenance and repair requiring the assistance of other skilled personnel shall be carried out under the supervision of the person competent in the use of flammable refrigerants.
- All working procedure that affects safety means shall only be carried by competent persons.
- Be careful not to bump when moving to avoid leakage in the refrigeration line.



**Flammable material.**

**This appliance contains R290/**

**Propane a flammable refrigerant**



**Refer operators  
manual**



**Read technical  
manual**



**Read operators**

## **The maximum dosage of refrigerant is 65g**

### **Notes:**

- The dehumidifier is only suitable for indoor use, and is not suitable for other applications.
- Place the machine in a flat and dry place and keep a distance of above 50cm between the machine and the surrounding objects or walls.
- After the dehumidifier is installed, ensure that the power plug is intact and firmly plugged into the power outlet, and place the power cord orderly to prevent someone from being tripped or pulling out the plug.
- Do not put any object into the air inlet and outlet of the dehumidifier. Keep the air inlet and outlet free from obstructions.
- When drainage pipes are installed, ensure that the drainage pipes are properly connected, and are not distorted or bended.
- When moving the machine, make sure that it is in an upright position.
- The machine should stay away from gasoline, flammable gas, stoves and other heat sources.
- Don't disassemble, overhaul and modify the machine arbitrarily, otherwise it will cause a machine malfunction or even bring harm to persons and properties. To avoid danger, if a machine failure occurs, ask the manufacturer or professionals to repair it.
- Do not pull the plug to turn off the machine.
- Do not place cups or other objects on the body to prevent water or other liquids from spilling into the dehumidifier.
- Do not use insecticide sprays or other flammable substances near the dehumidifier.
- Do not wipe or wash the dehumidifier with chemical solvents such as gasoline and alcohol. When you need to clean the air conditioning, you must disconnect the power supply, and clean it with a half-wet soft cloth. If the machine is really dirty, scrub with a mild detergent.
- This appliance is not intended for use by persons (including children) with reduced physical, sensory or mental capabilities, or lack of experience and knowledge, unless they have been given supervision or instruction concerning use of the appliance by a

person responsible for their safety. (Except for the humidifier with CE-MARKING)

- Children should be supervised to ensure that they do not play with the appliance. (Except for the humidifier with CE-MARKING)
- The appliance can be used by children aged from 8 years and above and persons with reduced physical, sensory or mental capabilities if they have been given supervision or instruction concerning use of the appliance in a safe way and understand the hazards involved. Children shall not play with the appliance. Cleaning and maintenance shall not be made by children without supervision (Only for the humidifier with CE-MARKING)
- If the supply cord is damaged, it must be replaced by the manufacturer, its service agent or similarly qualified persons in order to avoid a hazard.

### **Transportation, marking and storage for units**

1. Transport of equipment containing flammable refrigerants  
Compliance with the transport regulations
2. Marking of equipment using signs  
Compliance with local regulations
3. Disposal of equipment using flammable refrigerants  
Compliance with national regulations
4. Storage of equipment/appliances  
The storage of equipment should be in accordance with the manufacturer's instructions.
5. Storage of packed (unsold) equipment  
Storage package protection should be constructed such that mechanical damage to the equipment inside the package will not cause a leak of the refrigerant charge.

The maximum number of pieces of equipment permitted to be stored together will be determined by local regulations.

The appliance shall be stored so as to prevent mechanical damage from occurring

Remark:

The best operating ambient temperature is 5-35 ° C.

**The fuse mode is 4T or 4F or 334 or L3CT, the specification is AC250V, 3.15A.**

Appliance is filled with flammable gas R290, and the maximum charge of refrigerant is 65g. GWP value of R290refrigerant is 3.

Any repairs you need, contact the nearest authorized Service Centre and strictly follow manufacturer's instruction only

## **APPENDIX**

## **1. Information on servicing**

### 1) Checks to the area

Prior to beginning work on systems containing flammable refrigerants, safety checks are necessary to ensure that the risk of ignition is minimized. For repair to the refrigerating system, the following precautions shall be complied with prior to conducting work on the system.

### 2) Work procedure

Work shall be undertaken under a controlled procedure so as to minimize the risk of a flammable gas or vapor being present while the work is being performed.

### 3) General work area

All maintenance staff and others working in the local area shall be instructed on the nature of work being carried out. Work in confined spaces shall be avoided. The area around the workspace shall be sectioned off. Ensure that the conditions within the area have been made safe by control of flammable material.

### 4) Checking for presence of refrigerant

The area shall be checked with an appropriate refrigerant detector prior to and during work, to ensure the technician is aware of potentially flammable atmospheres. Ensure that the leak detection equipment being used is suitable for use with flammable refrigerants, i.e. non-sparking, adequately sealed or intrinsically safe.

### 5) Presence of fire extinguisher

If any hot work is to be conducted on the refrigeration equipment or any associated parts, appropriate fire extinguishing equipment shall be available to hand. Have a dry powder or CO<sub>2</sub> fire extinguisher adjacent to the charging area.

### 6) No ignition sources

No person carrying out work in relation to a refrigeration system which involves exposing any pipe work that contains or has contained flammable refrigerant shall use any sources of ignition in such a manner that it may lead to the risk of fire or explosion. All possible ignition sources, including cigarette smoking, should be kept sufficiently far away from the site of installation, repairing, removing and disposal, during which flammable refrigerant can possibly be released to the surrounding space.

Prior to work taking place, the area around the equipment is to be surveyed to make sure that there are no flammable hazards or ignition risks. “No Smoking” signs shall

be displayed.

#### 7) Ventilated area

Ensure that the area is in the open or that it is adequately ventilated before breaking into the system or conducting any hot work. A degree of ventilation shall continue during the period that the work is carried out. The ventilation should safely disperse any released refrigerant and preferably expel it externally into the atmosphere.

#### 8) Checks to the refrigeration equipment

Where electrical components are being changed, they shall be fit for the purpose and to the correct specification. At all times the manufacturer's maintenance and service guidelines shall be followed. If in doubt consult the manufacturer's technical department for assistance.

The following checks shall be applied to installations using flammable refrigerants:

- a) The charge size is in accordance with the room size within which the refrigerant containing parts are installed.
- b) The ventilation machinery and outlets are operating adequately and are not obstructed.
- c) If an indirect refrigerating circuit is being used, the secondary circuit shall be checked for the presence of refrigerant.
- d) Marking to the equipment continues to be visible and legible. Markings and signs that are illegible shall be corrected.
- e) Refrigeration pipe or components are installed in a position where they are unlikely to be exposed to any substance which may corrode refrigerant containing components, unless the components are constructed of materials which are inherently resistant to being corroded or are suitably protected against being so corroded.

#### 9) Checks to electrical devices

Repair and maintenance to electrical components shall include initial safety checks and component inspection procedures. If a fault exists that could compromise safety, then no electrical supply shall be connected to the circuit until it is satisfactorily dealt with. If the fault cannot be corrected immediately but it is necessary to continue operation, an adequate temporary solution shall be used. This shall be reported to the owner of the equipment so all parties are advised.

Initial safety checks shall include:

- a) That capacitors are discharged: this shall be done in a safe manner to avoid possibility of sparking.
- b) That there no live electrical components and wiring are exposed while charging, recovering or purging the system.
- c) That there is continuity of earth bonding.

## **2. Repairs to sealed components**

1) During repairs to sealed components, all electrical supplies shall be disconnected from the equipment being worked upon prior to any removal of sealed covers, etc. If it is absolutely necessary to have an electrical supply to equipment during servicing, then a permanently operating form of leak detection shall be located at the most critical point to warn of a potentially hazardous situation.

2) Particular attention shall be paid to the following to ensure that by working on electrical components, the casing is not altered in such a way that the level of protection is affected. This shall include damage to cables, excessive number of connections, terminals not made to original specification, damage to seals, incorrect fitting of glands, etc. Ensure that apparatus is mounted securely.

Ensure that seals or sealing materials have not degraded such that they no longer serve the purpose of preventing the ingress of flammable atmospheres.

Replacement parts shall be in accordance with the manufacturer's specifications.

**NOTE:** The use of silicon sealant may inhibit the effectiveness of some types of leak detection equipment. Intrinsically safe components do not have to be isolated prior to working on them.

## **3. Repair to intrinsically safe components**

Do not apply any permanent inductive or capacitance loads to the circuit without ensuring that this will not exceed the permissible voltage and current permitted for the equipment in use.

Intrinsically safe components are the only types that can be worked on while live in the presence of a flammable atmosphere. The test apparatus shall be at the correct rating.

Replace components only with parts specified by the manufacturer. Other parts may result in the ignition of refrigerant in the atmosphere from a leak.

## **4. Cabling**

Check that cabling will not be subject to wear, corrosion, excessive pressure,

vibration, sharp edges or any other adverse environmental effects. The check shall also take into account the effects of aging or continual vibration from sources such as compressors or fans.

### **5. Detection of flammable refrigerants**

Under no circumstances shall potential sources of ignition be used in the searching for or detection of refrigerant leaks. A halide torch (or any other detector using a naked flame) shall not be used.

### **6. Leak detection methods**

The following leak detection methods are deemed acceptable for systems containing flammable refrigerants.

Electronic leak detectors shall be used to detect flammable refrigerants, but the sensitivity may not be adequate, or may need re-calibration. (Detection equipment shall be calibrated in a refrigerant-free area.) Ensure that the detector is not a potential source of ignition and is suitable for the refrigerant used. Leak detection equipment shall be set at a percentage of the LFL of the refrigerant and shall be calibrated to the refrigerant employed and the appropriate percentage of gas (25 % maximum) is confirmed.

Leak detection fluids are suitable for use with most refrigerants but the use of detergents containing chlorine shall be avoided as the chlorine may react with the refrigerant and corrode the copper pipe-work.

If a leak is suspected, all naked flames shall be removed/ extinguished.

If a leakage of refrigerant is found which requires brazing, all of the refrigerant shall be recovered from the system, or isolated (by means of shut off valves) in a part of the system remote from the leak. Oxygen free nitrogen (OFN) shall then be purged through the system both before and during the brazing process.

### **7. Removal and evacuation**

When breaking into the refrigerant circuit to make repairs – or for any other purpose –conventional procedures shall be used. However, it is important that best practice is followed since flammability is a consideration. The following procedure shall be adhered to:

- 1) Remove refrigerant.
- 2) Purge the circuit with inert gas.

- 3) Evacuate.
- 4) Purge again with inert gas.
- 5) Open the circuit by cutting or brazing.

The refrigerant charge shall be recovered into the correct recovery cylinders. The system shall be “flushed” with OFN to render the unit safe. This process may need to be repeated several times. Compressed air or oxygen shall not be used for this task.

Flushing shall be achieved by breaking the vacuum in the system with OFN and continuing to fill until the working pressure is achieved, then venting to atmosphere, and finally pulling down to a vacuum. This process shall be repeated until no refrigerant is within the system. When the final OFN charge is used, the system shall be vented down to atmospheric pressure to enable work to take place. This operation is absolutely vital if brazing operations on the pipe-work are to take place.

Ensure that the outlet for the vacuum pump is not close to any ignition sources and there is ventilation available.

## **8. Charging procedures**

In addition to conventional charging procedures, the following requirements shall be followed.

- 1) Ensure that contamination of different refrigerants does not occur when using charging equipment. Hoses or lines shall be as short as possible to minimize the amount of refrigerant contained in them.
- 2) Cylinders shall be kept upright.
- 3) Ensure that the refrigeration system is earthed prior to charging the system with refrigerant.
- 4) Label the system when charging is complete (if not already).
- 5) Extreme care shall be taken not to overfill the refrigeration system.

Prior to recharging the system it shall be pressure tested with OFN. The system shall be leak tested on completion of charging but prior to commissioning. A follow up leak test shall be carried out prior to leaving the site.

## **9. Decommissioning**

Before carrying out this procedure, it is essential that the technician is completely familiar with the equipment and all its detail. It is recommended good practice that all refrigerants are recovered safely. Prior to the task being carried out, an oil and refrigerant sample shall be taken in case analysis is required prior to re-use of

reclaimed refrigerant. It is essential that electrical power is available before the task is commenced.

- 1) Become familiar with the equipment and its operation.
- 2) Isolate system electrically.
- 3) Before attempting the procedure ensure that:
  - a) Mechanical handling equipment is available, if required, for handling refrigerant cylinders.
  - b) All personal protective equipment is available and being used correctly.
  - c) The recovery process is supervised at all times by a competent person.
  - d) Recovery equipment and cylinders conform to the appropriate standards.
- 4) Pump down refrigerant system, if possible.
- 5) If a vacuum is not possible, make a manifold so that refrigerant can be removed from various parts of the system.
- 6) Make sure that cylinder is situated on the scales before recovery takes place.
- 7) Start the recovery machine and operate in accordance with manufacturer's instructions.
- 8) Do not overfill cylinders. (No more than 80 % volume liquid charge).
- 9) Do not exceed the maximum working pressure of the cylinder, even temporarily.
- 10) When the cylinders have been filled correctly and the process completed, make sure that the cylinders and the equipment are removed from site promptly and all isolation valves on the equipment are closed off.
- 11) Recovered refrigerant shall not be charged into another refrigeration system unless it has been cleaned and checked.

## **10. Labeling**

Equipment shall be labeled stating that it has been de-commissioned and emptied of refrigerant. The label shall be dated and signed. Ensure that there are labels on the equipment stating the equipment contains flammable refrigerant.

## **11. Recovery**

When removing refrigerant from a system, either for servicing or decommissioning, it is recommended good practice that all refrigerants are removed safely.

When transferring refrigerant into cylinders, ensure that only appropriate refrigerant recovery cylinders are employed. Ensure that the correct number of cylinders for holding the total system charge is available. All cylinders to be used are designated

for the recovered refrigerant and labeled for that refrigerant (i.e. special cylinders for the recovery of refrigerant). Cylinders shall be complete with pressure relief valve and associated shut-off valves in good working order. Empty recovery cylinders are evacuated and, if possible, cooled before recovery occurs.

The recovery equipment shall be in good working order with a set of instructions concerning the equipment that is at hand and shall be suitable for the recovery of flammable refrigerants. In addition, a set of calibrated weighing scales shall be available and in good working order. Hoses shall be complete with leak-free disconnect couplings and in good condition. Before using the recovery machine, check that it is in satisfactory working order, has been properly maintained and that any associated electrical components are sealed to prevent ignition in the event of a refrigerant release. Consult manufacturer if in doubt.

The recovered refrigerant shall be returned to the refrigerant supplier in the correct recovery cylinder, and the relevant Waste Transfer Note arranged. Do not mix refrigerants in recovery units and especially not in cylinders.

If compressors or compressor oils are to be removed, ensure that they have been evacuated to an acceptable level to make certain that flammable refrigerant does not remain within the lubricant. The evacuation process shall be carried out prior to returning the compressor to the suppliers. Only electric heating to the compressor body shall be employed to accelerate this process. When oil is drained from a system, it shall be carried out safely.



Correct Disposal of this product

This marking indicates that the product should not be disposed with other household wastes throughout the EU. To prevent possible harm to the environment or human health from uncontrolled waste disposal, recycle it responsibly to promote the sustainable reuse of material resources. To return your used device, please use the return and collection systems or contact the retailer where the product was purchased. They can take this product for environmentally safe recycling.